

LTZ50 SERIES

Robust linear units with guide

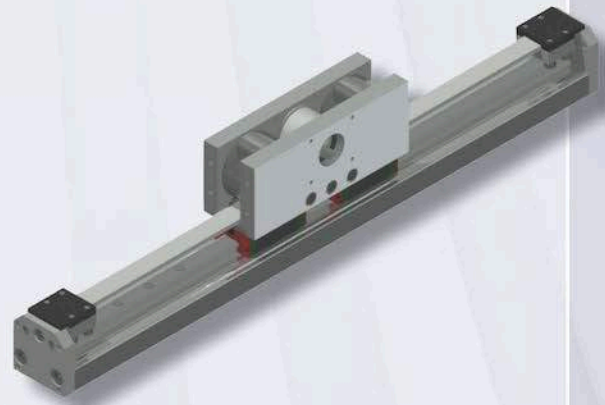

- Compact design, the width of the profile 50 mm
- Rail guide system, size -15-
- Double carriage design for high load
- Omega type belt for vertical applications
- Recirculating ball rail guide for heavy loads

TECHNICAL DATA

LTZ50-TR-S15D

Maximum stroke	mm	5.730
Maximum speed	mm/s	3.000
Maximum acceleration	m/s ²	30
No load torque	Nm	1,1
Repeatability	mm	± 0,1
Movement per revolution	mm	100

LTZ50 SERIES

TECHNICAL DATA

LOAD CAPACITY

LTZ50-TR-S15D

Mx	Nm	106
My	Nm	106
Mz	Nm	40
Fx	N	1.000
Fy	N	3.400
Fz	N	3.600

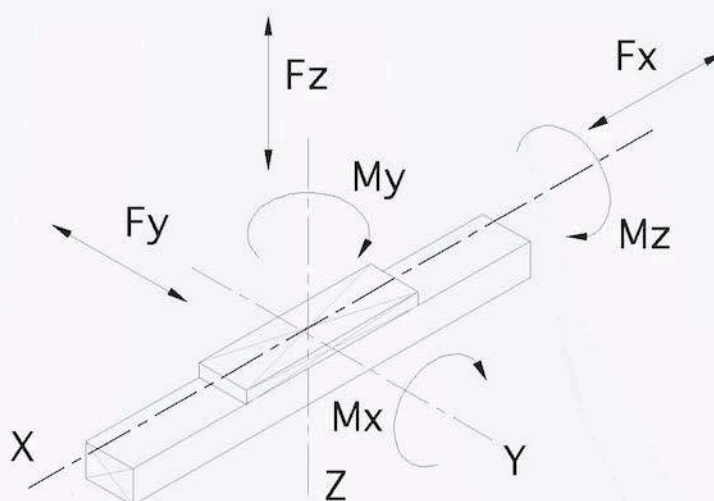

WEIGHTS (KG)

LTZ50-TR-S15D

Unit weight 0 mm stroke	2,53
Weight per 100 mm stroke	0,28

LTZ50 SERIES

DIMENSIONS

DIMENSIONS LTZ50-S15-D

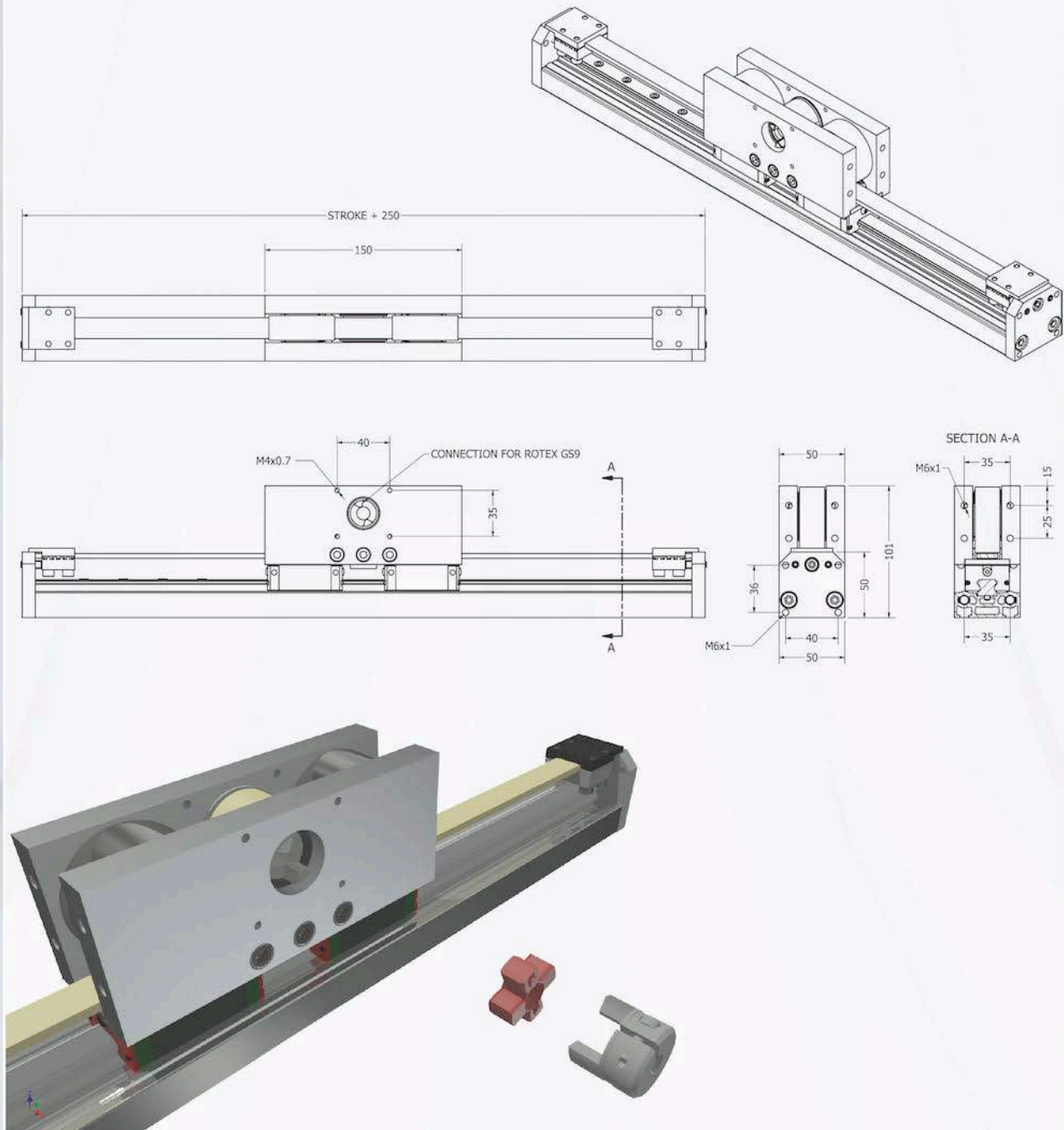

The LTZ50 Series is equipped with a pulley that has a connection for the Rotex GS9 flexible shaft coupling. This allows compact mounting of the gearbox / motor.