

LT50

MOTOR ACCESSORIES

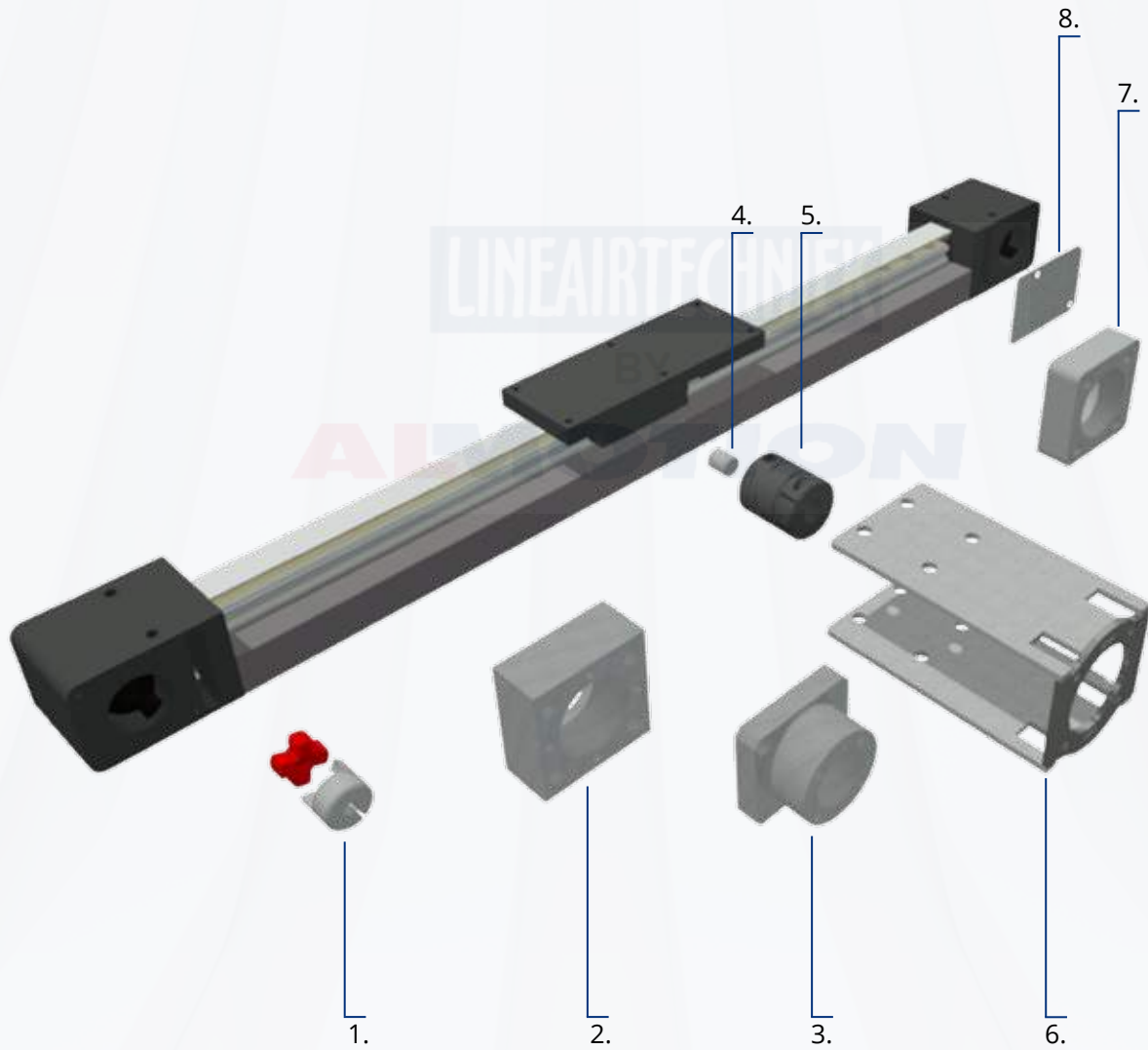

1	Rotex GS9-9/12	Flexible shaft coupling
2	5070-F-XXX	Motor adaptor
3	5070-FL-XXX	Motor adaptor
4	5070-AS10	Interface shaft
5	Rotex GS14-10-14	Flexible shaft coupling
6	5070-F9/14-XXX	Adaptor for motor shaft 14
7	5070-FL-NEMA23	Motor adapter
8	5070-BP	Blank coverplate-ss

LT50-TR-S15(D)

ACCESSORIES

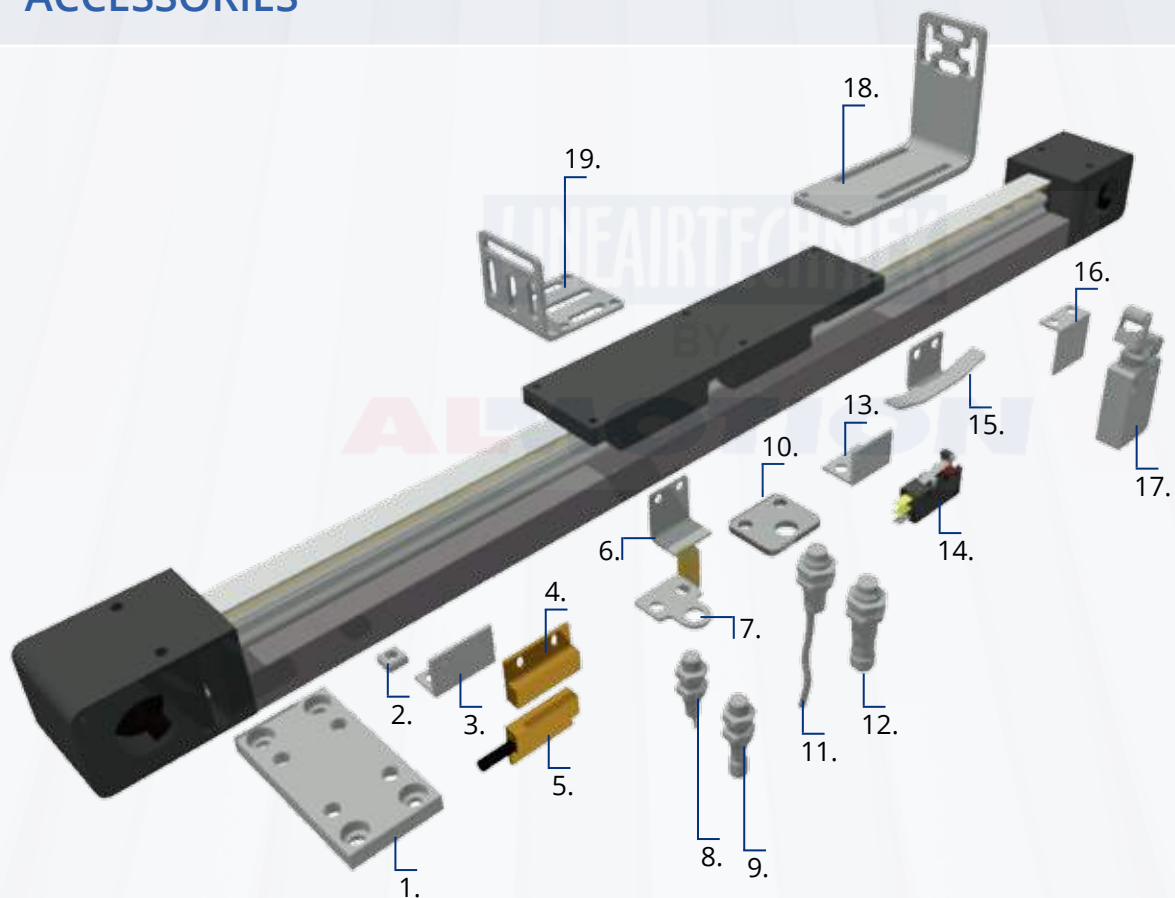

1	5070-MP-W	Mounting bracket
2	50.1330	Square nut M5
3	5070-GM-MAG	Bracket for magnetic sensor
4	1368	Magnet
5	289 Sensor	Reed switch
6	5070-DG-IN	Sensor bracket inductive
7	5070-SG-XS8	Bracket for M8 sensor
8	XS4p08pa340	M8 inductive sensor-cable
9	XS4p08pa340s	M8 inductive sensor-M8
10	7070-SG-XS12	Bracket for M12 sensor
11	XS212b4pbm	M12 inductive sensor-M8
12	XS212b4pal	M12 inductive sensor-cable
13	5070-GM-SH	Bracket for switch
14	SPDT-V3-	Omron switch
15	5070-SD-ME	Bracket for Roll switch
16	5070-SG-SH	Bracket for switch
17	XCMD2117L1	Mechanical switch Roll
18	5070-BB-L	Bracket for endcap mounting
19	5070-HS-50	Bracket for carriage