

LT2

MOTOR ACCESSORIES

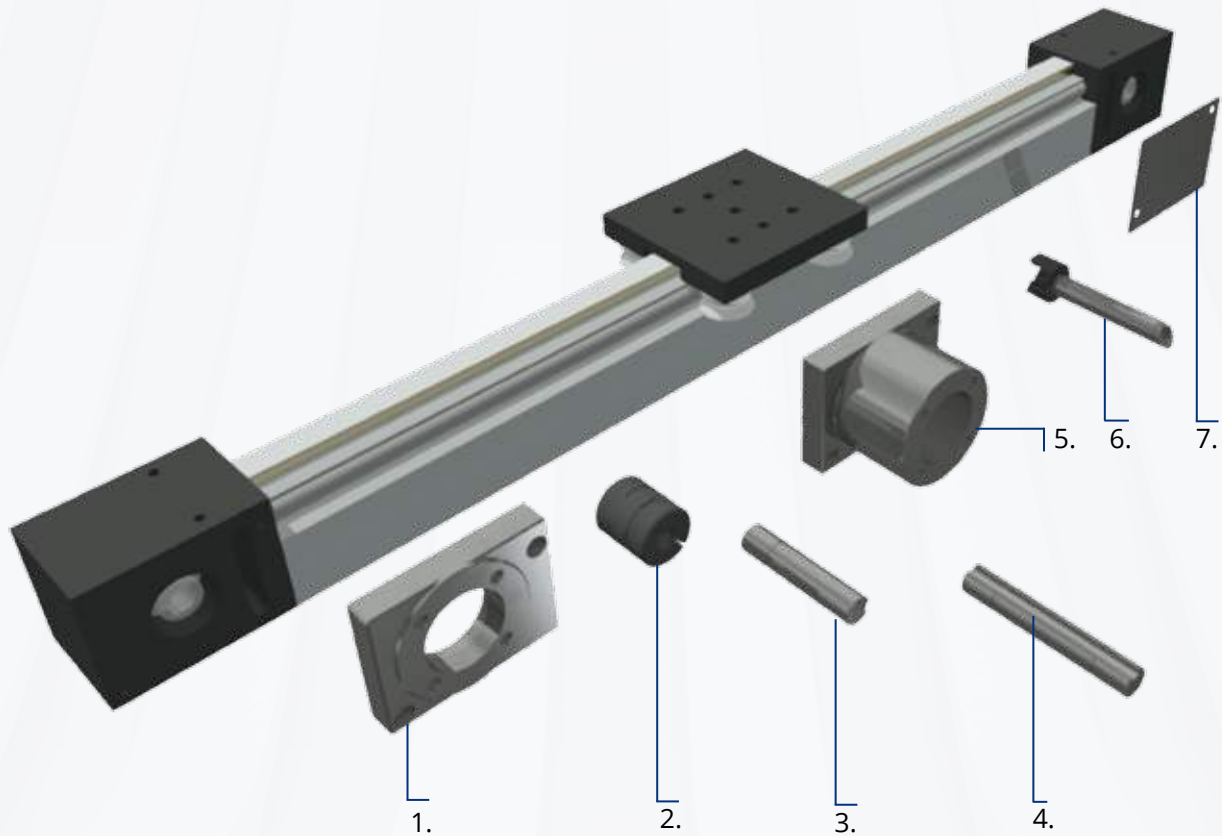

1	7070-T-XXX	Motor flange
2	Rotex GS14	Flexible coupling
3	7070-SH-14	Motor shaft 1 side
4	7070-SH-14D	Motor shaft 2 sides
5	7070-FL-XX	Motor adapter
6	7070-VA-14-XXX	Coupling shaft
7	7070-BP	Blanking cover plate

LT2-TR-C8

ACCESSORIES

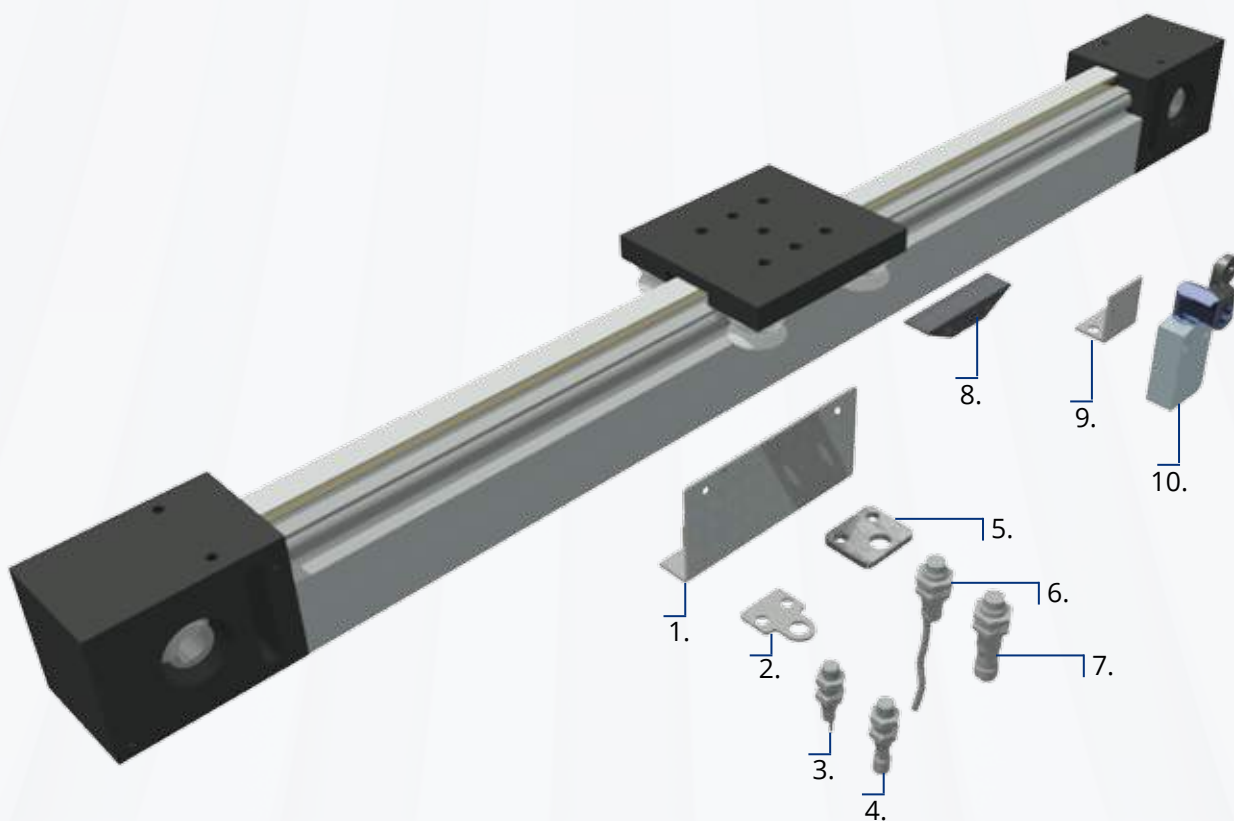

1	7070-DG8-IN	Sensor bracket
2	7070-SG-XS8	Bracket for M8 sensor
3	XS4p08pa340	M8 inductive sensor-cable
4	XS4p08pa340s	M8 inductive sensor-M8
5	7070-SG-XS12	Bracket for M12 sensor
6	XS212b4pal	M12 inductive sensor-cable
7	XS212b4pbm	M12 inductive sensor-M8
8	7070-SG-ME	Bracket for roll switch
9	7070-SA-SH	Bracket for switch
10	XCMD2117L1	Mechanical switch roll